



# BURNERS

**baltur** **75**   
Energy for People 1950 - 2025



TBG 80 - 160 SLX ME

SUPER LOW NOx  
- FIR - BURNERS

	TBG 80 SLX ME	TBG 100 SLX ME	TBG 160 SLX ME
<b>Gas burner compliant with European standard EN676. Operation:</b>	<b>electronic modulation</b>	<b>electronic modulation</b>	<b>electronic modulation</b>
P.I.D. controller and signal receiver (0÷10V / 4÷20 mA) integrated in burner control panel	○	○	○
Modulation ratio	1 : 5	1 : 7	1 : 10
Low NOx and CO emissions gas burner according to European standard EN676:	class 4	class 4	class 4
72 h continuous operation	○	○	○
Adjusting the combustion head	●	●	●
Maintenance facilitated by the possibility of removing the mixing unit without having to remove the burner from the boiler	●	●	●
Fixed coupling flange	●	●	●
Easy maintenance thanks to the two-sides hinge which allows the removal of the combustion head without having to remove the burner from the boiler	●	●	●
Combustion air intake with butterfly valve. Air flow adjustment:	electric servomotor	electric servomotor	electric servomotor
Fully closing air damper on shutdown to avoid loss of heat through the chimney	●	●	●
Device made of sound-absorbing material to reduce fan noise	●	●	●
CE version gas train is complete with operation and safety valve with electromagnetic drive, maximum and minimum pressure switch with gas leakage control, pressure regulator and gas filter	●	●	●
Fail proof connectors for burner/gas train connection	●	●	●
Gas train outlet:	up/down	up/down	up/down
Secondary gas train outlet:	right/left	right/left	right/left
Flame detection by ionisation electrode with connector for microamperometer	●	●	●
Control panel equipped either with display showing the working process and with the keyboard for the burner adjustment	●	●	●
Electric protection rating:	IP40	IP40	IP40
Noise level dB(A)	74	75	79
Residual oxygen (O <sub>2</sub> ) monitoring in the fumes in order to maintain an optimal air/fuel ratio and ensure increased performance	○	○	○
Residual oxygen (O <sub>2</sub> ) and carbon monoxide (CO) and monitoring of oxidizing components (H <sub>2</sub> ) in fumes to ensure increased performance and less atmospheric pollution	○	○	○
VDS fan motor to reduce overall electrical power consumption	○	○	○

**LEGEND:**

○ Optional; ● As standard

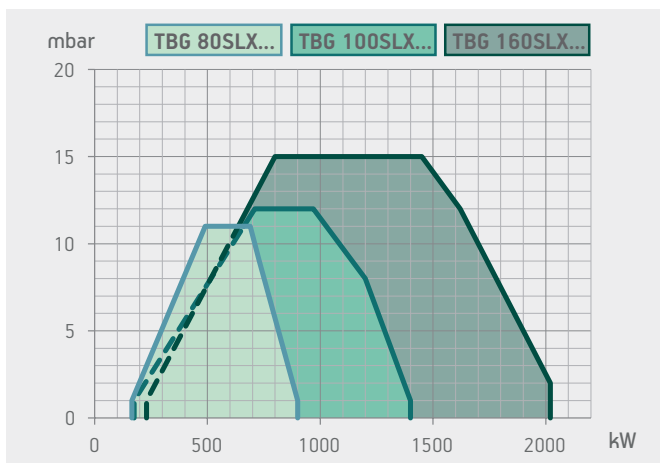

Model	Size of packaging			Weight kg
	L	P mm	H	
TBG 80 SLX	1130	800	663	98,5
TBG 100 SLX	1130	800	663	103
TBG 160 SLX	1130	800	663	106

SUPER LOW NOX  
- FIR - BURNERS

TBG 80 - 160 SLX ME

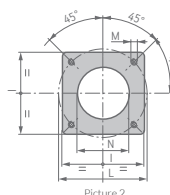
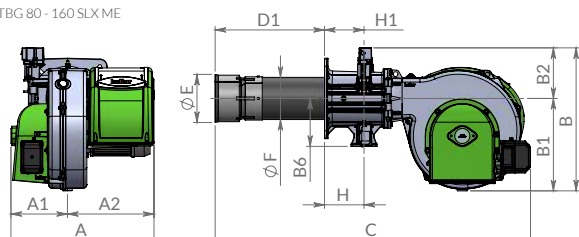

Flange dimensions  
and boiler drilling  
template.

Model	A mm	A1 mm	A2 mm	B mm	B1 mm	B2 mm	B6 mm	C mm	D mm	E mm	F mm	I mm	H mm	H1 mm	L mm	M mm	N mm	Pic.
TBG 80 SLX	597	237	360	594	386	211	200	1289	448	201	176	328	165	165	278-378	M12	216	2
TBG 100 SLX	597	237	360	594	386	211	200	1289	448	201	176	328	167	165	278-378	M12	216	2
TBG 160 SLX	597	237	360	594	386	211	200	1294	453	250	225	328	167	165	278-378	M12	254	2

	Emissions class	Thermal output kW	Model	Part no.	Electrical supply	Motor kW	Notes
Frequency 50 Hz							
	class 4	165 ÷ 900	<b>TBG 80 SLX</b>	<b>18240010</b>	3N AC 50Hz 400V	1,5	3) 4)
	class 4	175 ÷ 1400	<b>TBG 100 SLX</b>	<b>18260010</b>	3N AC 50Hz 400V	2,2	3) 4)
	class 4	230 ÷ 2020	<b>TBG 160 SLX</b>	<b>18280010</b>	3N AC 50Hz 400V	3	3) 4)
Frequency 60 Hz							
	class 4	165 ÷ 900	<b>TBG 80 SLX</b>	<b>18245410</b>	3N AC 60Hz 380V	1,5	3) 4)
	class 4	175 ÷ 1400	<b>TBG 100 SLX</b>	<b>18265410</b>	3N AC 60Hz 380V	2,2	3) 4)
	class 4	230 ÷ 2020	<b>TBG 160 SLX</b>	<b>18285410</b>	3N AC 60Hz 380V	3	3) 4)

### TO COMPLETE THE BURNER

DESCRIPTION	PART NO.
Modulating kit	98000059
Modulating probe for LCM 100 (see page 8)	
TBG 80 SLX: LPG nozzle kit 2)	98000447
TBG 100 SLX: LPG nozzle kit 2)	98000448
TBG 160 SLX: LPG nozzle kit 2)	98000449

### NOTE

- 2 Please contact your Sales Representative for the LPG application.
  - 3 Sound proof lid on burner air intake.
  - 4 Equipped with automatic air closure device.
- Net calorific value at reference conditions of 0°C, 1013mbar:  
 Natural gas: Hi = 35,80 MJ/m<sup>3</sup> = 8550 kcal/m<sup>3</sup>,  
 LPG: Hi = 92 MJ/m<sup>3</sup> = 22000 kcal/m<sup>3</sup>.  
 For different type of gas and pressure values, please get in contact with our commercial department.

### ACCESSORIES AVAILABLE ON REQUEST

DESCRIPTION	PART NO.
O2 control kit <b>NEW</b>	98000460
CO control kit <b>NEW</b>	98000461
Soundproof burner cover (see page 12)	

### BURNER ACCESSORIES

Boiler coupling kit, plug for wiring



TBG 320 SLX ME



TBG 480 SLX ME

SUPER LOW NOx  
- FIR - BURNERS

### TBG 320 SLX ME

### TBG 480 SLX ME

#### Gas burner compliant with European standard EN676. Operation:

	electronic modulation	electronic modulation
P.I.D. controller and signal receiver (0÷10V / 4÷20 mA) integrated in burner control panel	○	○
Modulation ratio	1 : 7	1 : 8
Low NOx and CO emissions gas burner according to European standard EN676:	class 4	class 4
72 h continuous operation	○	○
Adjusting the combustion head	●	●
Maintenance facilitated by the possibility of removing the mixing unit without having to remove the burner from the boiler	●	●
Fixed coupling flange	●	●
Easy maintenance thanks to the two-sides hinge which allows the removal of the combustion head without having to remove the burner from the boiler	●	●
Combustion air intake with butterfly valve. Air flow adjustment:	electric servomotor	electric servomotor
Fully closing air damper on shutdown to avoid loss of heat through the chimney	●	●
Device made of sound-absorbing material to reduce fan noise	●	●
CE version gas train is complete with operation and safety valve with electromagnetic drive, maximum and minimum pressure switch with gas leakage control, pressure regulator and gas filter	●	●
Fail proof connectors for burner/gas train connection	●	●
Gas train outlet:	up/down	up/down
Secondary gas train outlet:	up/down	up/down
Flame detection by ionisation electrode with connector for microamperometer	●	●
Control panel equipped either with display showing the working process and with the keyboard for the burner adjustment	●	●
Electric protection rating:	IP54	IP54
Noise level dB(A)	81	88
Residual oxygen (O <sub>2</sub> ) monitoring in the fumes in order to maintain an optimal air/fuel ratio and ensure increased performance	○	○
Residual oxygen (O <sub>2</sub> ) and carbon monoxide (CO) and monitoring of oxidizing components (H <sub>2</sub> ) in fumes to ensure increased performance and less atmospheric pollution	○	○
VDS fan motor to reduce overall electrical power consumption	○	○

#### LEGEND:

○ Optional; ● As standard



## BURNER/GAS TRAIN MATCH

SUPER LOW NOX  
- FIR - BURNERS

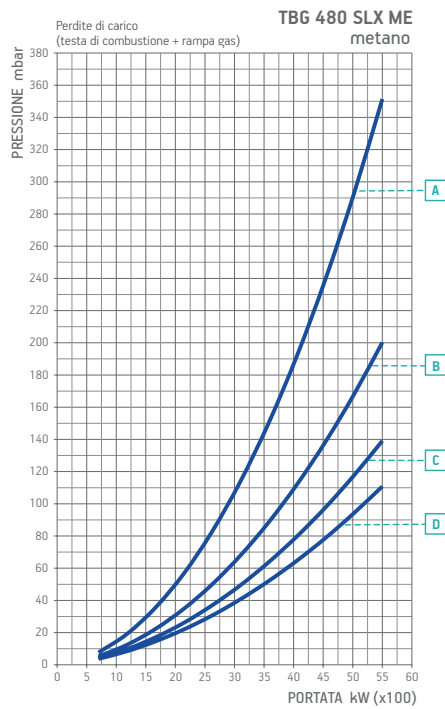
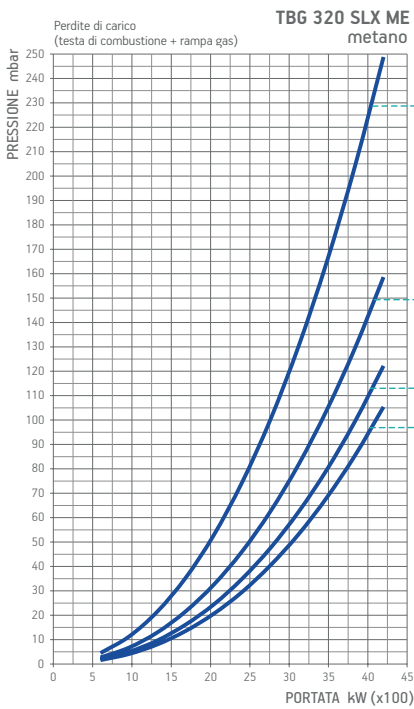
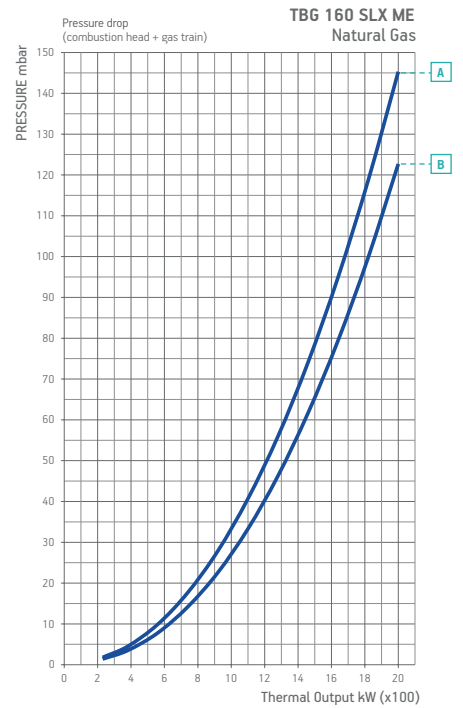
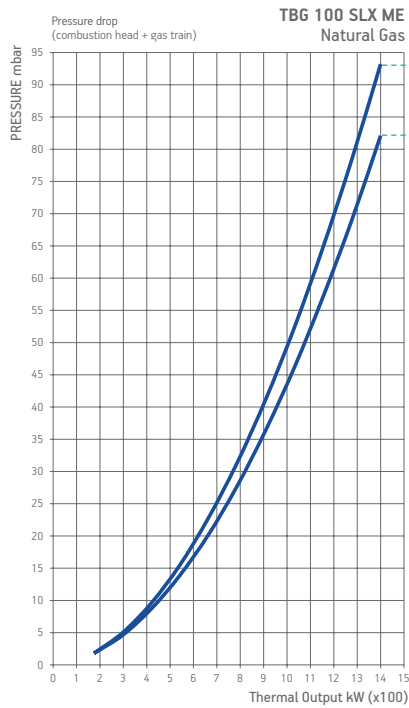
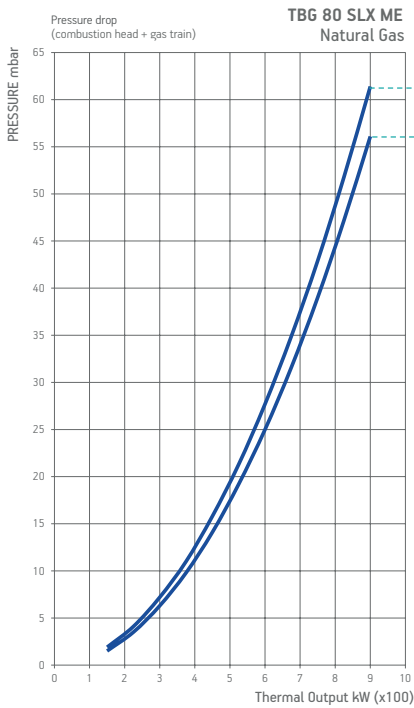

## BURNER/GAS TRAIN MATCH

CE GAS TRAIN VERSION COMPLIES WITH EN676, EXP GAS TRAIN VERSION IS FOR EXTRA-EUROPEAN MARKETS.

Burner model	Gas type	Curve on graph	Version	P.Max ** mbar	Execution	Gas train	Regulator with incorporated filter	Burner/gas train adapter	Valve tightness control kit	Pic.	Notes
						Part no.	Part no.	Part no.	Part no.		
TBG 80 SLX	Natural gas	A	CE/EXP	200	CTV	19990667	Included	-	Included	F1	
		B	CE/EXP	200	CTV	19990668	Included	-	Included	F1	
		B	CE/EXP	200	CTV	19990734	Included	-	Included	F1	
TBG 100 SLX	Natural gas	A	CE/EXP	200	CTV	19990667	Included	-	Included	F1	
		B	CE/EXP	200	CTV	19990668	Included	-	Included	F1	
		B	CE/EXP	200	CTV	19990734	Included	-	Included	F1	
TBG 160 SLX	Natural gas	A	CE/EXP	200	CTV	19990667	Included	-	Included	F1	
		B	CE/EXP	200	CTV	19990668	Included	-	Included	F1	
		B	CE/EXP	200	CTV	19990734	Included	-	Included	F1	
TBG 320 SLX	Natural gas	A	CE/EXP	500	CTV	19990675	Included	-	Included	F1	
		B	CE/EXP	500	CTV	19990676	Included	-	Included	F1	
		C	CE/EXP	500	CTV	19990677	Included	-	Included	F1	
		D	CE/EXP	500	CTV	19990678	Included	-	Included	F1	
		B	CE/EXP	500	CTV	19990762	Included	-	Included	F1	
		C	CE/EXP	500	CTV	19990763	Included	-	Included	F1	
		D	CE/EXP	500	CTV	19990764	Included	-	Included	F1	
TBG 480 SLX	Natural gas	A	CE/EXP	500	CTV	19990675	Included	-	Included	F1	
		B	CE/EXP	500	CTV	19990676	Included	-	Included	F1	
		C	CE/EXP	500	CTV	19990677	Included	-	Included	F1	
		D	CE/EXP	500	CTV	19990678	Included	-	Included	F1	
		B	CE/EXP	500	CTV	19990762	Included	-	Included	F1	
		C	CE/EXP	500	CTV	19990763	Included	-	Included	F1	
		D	CE/EXP	500	CTV	19990764	Included	-	Included	F1	

SUPER LOW NOX  
- FIR - BURNERS

## NOTES

CTV Gas train with Valve Tightness Control.

\*\*) Maximum gas inlet pressure at pressure regulator.

# MODULATION

The two stage progressive burners, by installing the PID load controller and related modulating kit, can operate as modulating burners with the ability to adjust the thermic load according to boiler needs. The load adjustment is possible between the minimum and maximum burner's operating point.

### How to choose the modulating kit components:

According to the parameter that it's necessary to control: temperature (°C) or pressure (bar) it's necessary to choose the range kit according to boiler operating range.

In case the value is included in two ranges it's necessary to select the lower range.

### Example:

In case the required hot water boiler set point is 100°C it's necessary to select the temperature probe kit with operating range between 0 ÷ 130°C.

In case the steam boiler must operate with 8bar outlet steam pressure it's necessary to select the pressure probe kit with operating range between 0 ÷ 10 bar.



### Automatic proportional modulation regulator PID

Part no.	Kit	Burners
98000055	Modulation kit LC3	TBG 450 ÷ 2000 MC
98000056	Modulation kit LC3	TBG 35 MC
98000057	Modulation kit LC3	TBML 80 ÷ 360 MC
98000058	Modulation kit LC3	TBG 45 ÷ 60 MC
98000059	Modulation kit LCM 100	ME models
98000065	Modulation kit LC4	TBG 80 ÷ 360 MC

### Temperature probe for LC3 modulation

Part no.	Temperature	Type robe	Probe length	Male coupling
98000023	0 °C ÷ 130 °C	PT 1000	85 <sup>1)</sup>	R 1/2"
98000021	0 °C ÷ 500 °C	PT 1000	200 <sup>1)</sup>	G 1/2"
98000022	0 °C ÷ 1100 °C	Thermocouple	425 <sup>1)</sup>	R 1/2"



### Temperature probe for LCM 100 modulation

Part no.	Temperature	Type robe	Probe length	Male coupling
98000023	0 °C ÷ 130 °C	PT 1000	85 <sup>1)</sup>	R 1/2"
98000021	0 °C ÷ 500 °C	PT 1000	200 <sup>1)</sup>	G 1/2"

### Temperature probe for ETAMATIC OEM control box

Part no.	Temperature	Type robe	Probe length	Male coupling
98000035	0 °C ÷ 500 °C	PT 100	100 <sup>1)</sup>	G 1/2"



### Steam pressure probe (for all types of automatic regulator)\*

Part no.	Pressure steam	Signal output	Male coupling
98000045	0 ÷ 1 bar	4 ÷ 20 mA	G 1/2"
98000046	0 ÷ 10 bar	4 ÷ 20 mA	G 1/2"
98000047	0 ÷ 16 bar	4 ÷ 20 mA	G 1/2"
98000048	0 ÷ 25 bar	4 ÷ 20 mA	G 1/2"
98000049	0 ÷ 40 bar	4 ÷ 20 mA	G 1/2"

\*) In the case of using applications where temperatures exceed 90°C you need to match the kit codes: 98000062

**NOTE: In combination with the LC4 modulation kit for MC models, a 12V power supply kit is mandatory.**

98000482	12V power supply kit
----------	----------------------

### External climate regulation

Part no.	Description	Temperature
85060070	Temperature probe PT100	-50 °C ÷ 90 °C
98000061	Interface module for LC3	

### Power signal converter (TBG 45÷360 MC / LX MC)

Part no.	Description
98000063	Converter kit 0 ÷ 10 V / 4 ÷ 20 mA

### UV safe kit

Part no.	Description
98000443	UV SAFE KIT TBG 80-360 FGR
98000444	UV SAFE KIT TBG 450-750 FGR
98000445	UV SAFE KIT TBG 800 FGR
98000446	UV SAFE KIT TBG 1200 FGR

Note: For different modulation values please contact our Technical Assistance Service.

1) Different lengths on request.

## Gas pressure regulator with incorporated filter approved CE\*

Control closing , pressure taps upstream side - the side valley , safety diaphragm.

Max inlet pressure : 1 bar.

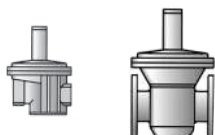

Part no.	Model	Outlet pressure mbar	Gas connection
97392010	BTFR/1	40 ÷ 110	1/2"
97392020	BTFR/1	40 ÷ 110	3/4"
97392030	BTFR/1	40 ÷ 110	1"
97392040	BTFR/1	90 ÷ 190	1"1/4
97392050	BTFR/1	90 ÷ 190	1"1/2
97392060	BTFR/1	90 ÷ 190	2"
97392070	BTFR/1	110 ÷ 200	DN65 - PN16
97392080	BTFR/1	110 ÷ 200	DN80 - PN16
97392090	BTFR/1	130 ÷ 200	DN100 - PN16

## CE gas pressure regulator CE\*

Control closing , pressure taps upstream side - the side valley , safety diaphragm.

Max inlet pressure : 1 bar.



Part no.	Model	Outlet pressure mbar	Gas connection
97392100	BTR/1	100 ÷ 250	DN125 - PN16
97392110	BTR/1	100 ÷ 250	DN150 - PN16

## Gas pressure regulator with incorporated filter approved CE\*

Control closing , pressure taps upstream side - the side valley , safety diaphragm.

Max inlet pressure : 2 bar.

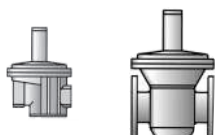

Part no.	Model	Outlet pressure mbar	Gas connection
97392210	BTFR/2	40 ÷ 110	1/2"
97392220	BTFR/2	40 ÷ 110	3/4"
97392230	BTFR/2	40 ÷ 110	1"
97392240	BTFR/2	90 ÷ 190	1"1/4
97392250	BTFR/2	90 ÷ 190	1"1/2
97392260	BTFR/2	90 ÷ 190	2"
97392270	BTFR/2	110 ÷ 200	DN65 - PN16
97392280	BTFR/2	110 ÷ 200	DN80 - PN16
97392290	BTFR/2	130 ÷ 200	DN100 - PN16

## Gas pressure regulator with incorporated filter approved CE\*

Control closing , pressure taps upstream side - the side valley , safety diaphragm.

Max inlet pressure : 6 bar.

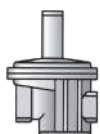

Part no.	Model	Outlet pressure mbar	Gas connection
97392310	BTFR/6	30 ÷ 90	1/2"
97392320	BTFR/6	30 ÷ 90	3/4"
97392330	BTFR/6	30 ÷ 90	1"

## CE gas pressure regulator CE\*

Control closing , pressure taps upstream side - the side valley , safety diaphragm.

Max inlet pressure : 6 bar.

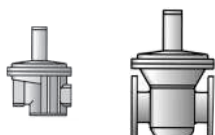

Part no.	Model	Outlet pressure mbar	Gas connection
97392340	BTR/6	85 ÷ 180	1"1/4
97392350	BTR/6	85 ÷ 180	1"1/2
97392360	BTR/6	85 ÷ 180	2"
97392370	BTR/6	110 ÷ 200	DN65 - PN16
97392380	BTR/6	110 ÷ 200	DN80 - PN16
97392390	BTR/6	110 ÷ 200	DN100 - PN16

\* ) All the pressure regulators in these pages have a standard spring with its own adjustment field. For different delivery pressures, the table below shows the regulation field that must be used, as well as the corresponding spring to replace the standard one with.

# ACCESSORIES FOR CONNECTION OF BURNERS TO GAS MAINS

## PRESSURE REGULATOR SPRINGS

		1/2"	3/4"	1"	1"1/4	1"1/2	2"	DN 65	DN 80	DN 100	DN 125	DN 150							
PRESSURE INPUT 1bar	regulator code	97392010	97392020	97392030	97392040	97392050	97392060	97392070	97392080	97392090	97392100	97392110							
	code spring	97399002	97399005	97399007	97399008	97399009	97399010	97399011	97399012	97399013	97399014	97399015	97399016	97399017	97399018	97399019	97399020	97399021	97399022
		9 ÷ 28	9 ÷ 28	9 ÷ 28															
		18 ÷ 40	18 ÷ 40	18 ÷ 40															
					13 ÷ 23	13 ÷ 23	13 ÷ 23												
		<b>40 ÷ 110*</b>	<b>40 ÷ 110*</b>	<b>40 ÷ 110*</b>															
					20 ÷ 36	20 ÷ 36	20 ÷ 36												
		110 ÷ 150	110 ÷ 150	110 ÷ 150															
		150 ÷ 200	150 ÷ 200	150 ÷ 200	33 ÷ 58	33 ÷ 58	33 ÷ 58												
					55 ÷ 100	55 ÷ 100	55 ÷ 100												
									13 ÷ 27	13 ÷ 27	15 ÷ 27								
									22 ÷ 50	22 ÷ 50	22 ÷ 55								
		200 ÷ 600	200 ÷ 600	200 ÷ 600															
					<b>90 ÷ 190*</b>	<b>90 ÷ 190*</b>	<b>90 ÷ 190*</b>												
									50 ÷ 130	50 ÷ 130	55 ÷ 130								
								<b>110 ÷ 200*</b>	<b>110 ÷ 200*</b>	<b>130 ÷ 200*</b>									
											20 ÷ 150	20 ÷ 150							
											<b>100 ÷ 250*</b>	<b>100 ÷ 250*</b>							
											230 ÷ 350	230 ÷ 350							
											300 ÷ 450	300 ÷ 450							
PRESSURE INPUT 2 bar	regulator code	97392210	97392220	97392230	97392240	97392250	97392260	97392270	97392280	97392290									
	code spring	97399001	97399005	97399008	97399010	97399011	97399012	97399013	97399014	97399015	97399016	97399017	97399018						
		9 ÷ 22	9 ÷ 22	9 ÷ 22															
		20 ÷ 40	20 ÷ 40	20 ÷ 40															
		<b>40 ÷ 110*</b>	<b>40 ÷ 110*</b>	<b>40 ÷ 110*</b>	12 ÷ 35	12 ÷ 35	12 ÷ 35												
		110 ÷ 150	110 ÷ 150	110 ÷ 150	30 ÷ 50	30 ÷ 50	30 ÷ 50												
		150 ÷ 200	150 ÷ 200	150 ÷ 200	40 ÷ 60	40 ÷ 60	40 ÷ 60												
					60 ÷ 95	60 ÷ 95	60 ÷ 95												
									13 ÷ 27	13 ÷ 27	15 ÷ 27								
									22 ÷ 50	22 ÷ 50	27 ÷ 55								
	200 ÷ 600	200 ÷ 600	200 ÷ 600																
				<b>90 ÷ 190*</b>	<b>90 ÷ 190*</b>	<b>90 ÷ 190*</b>													
								50 ÷ 130	50 ÷ 130	55 ÷ 130									
								<b>110 ÷ 200*</b>	<b>110 ÷ 200*</b>	<b>130 ÷ 200*</b>									
PRESSURE INPUT 6 bar	regulator code	97392310	97392320	97392330	97392340	97382350	97392360	97392370	97392380	97392390									
	code spring	97399003	97399004	97399006	97399009	97399011	97399012	97399013	97399014	97399016	97399017	97399018							
		20 ÷ 30	20 ÷ 30	20 ÷ 30															
		<b>30 ÷ 90*</b>	<b>30 ÷ 90*</b>	<b>30 ÷ 90*</b>															
		90 ÷ 170	90 ÷ 170	90 ÷ 170															
					15 ÷ 33	15 ÷ 33	15 ÷ 33												
					32 ÷ 60	32 ÷ 60	32 ÷ 60												
					50 ÷ 95	50 ÷ 95	50 ÷ 95												
									13 ÷ 27	13 ÷ 27	13 ÷ 22								
									22 ÷ 58	22 ÷ 58	18 ÷ 40								
				<b>85 ÷ 180*</b>	<b>85 ÷ 180*</b>	<b>85 ÷ 180*</b>													
								50 ÷ 130	50 ÷ 130	25 ÷ 120									
								<b>110 ÷ 200*</b>	<b>110 ÷ 200*</b>	<b>110 ÷ 200*</b>									

\*) of series.

## ACCESSORIES FOR CONNECTION OF BURNERS TO GAS MAINS

### Gas filters approved CE

With pressure.

Max inlet pressure: 2 bar.



Part no.	Model	Gas connection
97410001	BTF	1/2" FF
97410002	BTF	3/4" FF
97410003	BTF	1" FF
97410004	BTF	1" 1/4 FF
97410005	BTF	1" 1/2 FF
97410006	BTF	2" FF
97419999	BTF	DN65 - PN16
97429999	BTF	DN80 - PN16
97439999	BTF	DN100 - PN16
97459999	BTF	DN125 - PN16
97449999	BTF	DN150 - PN16

### Gas filters approved CE

With pressure.

Max inlet pressure: 6 bar.

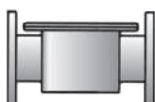

Part no.	Model	Gas connection
97410010	BTF/6	1" 1/4" FF
97410011	BTF/6	1" 1/2" FF
97410012	BTF/6	2" FF
97410013	BTF/6	DN65 - PN16
97410014	BTF/6	DN80 - PN16
97410015	BTF/6	DN100 - PN16

### Anti-vibration and compensation joints approved CE

DIN 30681 stainless steel.



Part no.	Model	Gas connection
97029999	BTGA	1/2" MM
97039999	BTGA	3/4" MM
97049999	BTGA	1" MM
97059999	BTGA	1" 1/4" MM
97069999	BTGA	1" 1/2" MM
97079999	BTGA	2" MM
97089999	BTGA	DN65 - PN16
97099999	BTGA	DN80 - PN16
97109999	BTGA	DN100 - PN16
97119999	BTGA	DN125 - PN16
97129999	BTGA	DN150 - PN16

### Ball valves approved CE

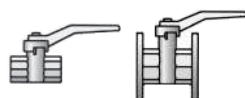

Part no.	Model	Gas connection
97679999	BTVS	3/8" FF
97689999	BTVS	1/2" FF
97699999	BTVS	3/4" FF
97709999	BTVS	1" FF
97719999	BTVS	1" 1/4" FF
97729999	BTVS	1" 1/2" FF
97739999	BTVS	2" FF
97749999	BTVS	DN65 - PN16
97759999	BTVS	DN80 - PN16
97769999	BTVS	DN100 - PN16
97179999	BTVS	DN125 - PN16
97189999	BTVS	DN150 - PN16

# SOUNDPROOF BURNER

Average sound pressure reduction of about 10 dB(A) measured in a laboratory with 1 meter microphone from the burner.

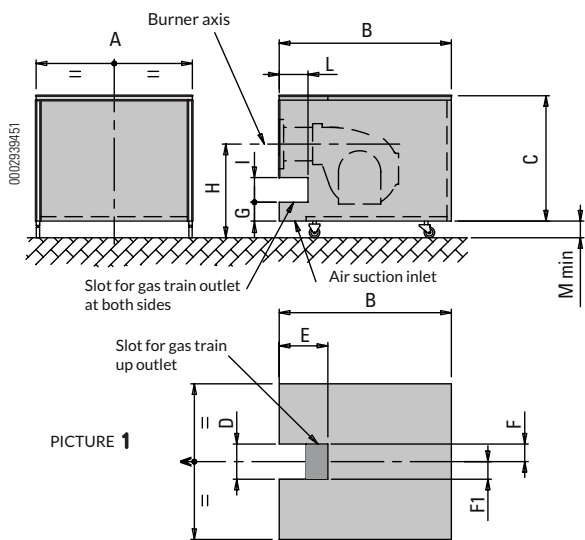

PICTURE 1

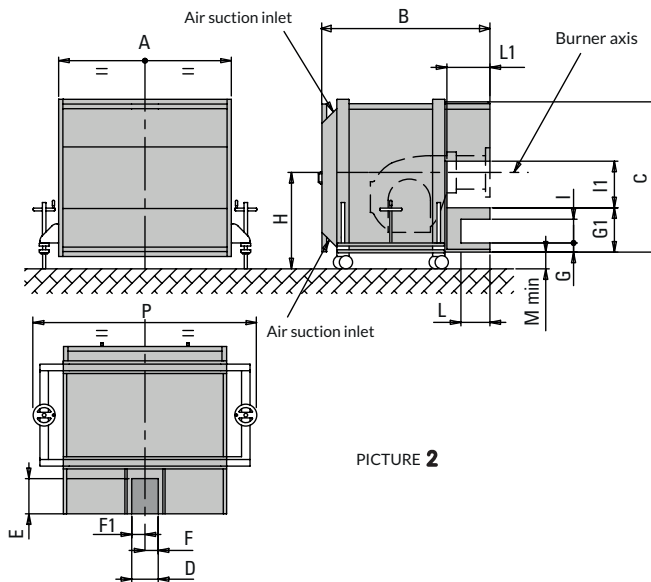

PICTURE 2

Model	Sound pressure	Pic.	A	B	C	D	E	F	F1	G	G1	H mm		I	I1	L	L1	M min	P
			mm	mm	mm	mm	mm	mm	mm	mm	mm	mm	mm	min	max	mm	mm	mm	mm
97980053*	-10 dB(A)	1	1100	1340	860	85	500	42,5	42,5	207	-	660	1350	85	-	500	-	190	-
97980054	-10 dB(A)	1	750	1080	650	85	380	42,5	42,5	157	-	560	1060	85	-	355	-	190	-
97980055	-10 dB(A)	1	1100	1340	860	85	440	42,5	42,5	-	-	650	1300	-	-	-	-	190	-
97980057	-10 dB(A)	1	1335	1655	1130	210	495	47,5	162,5	-	-	900	1700	-	-	-	-	190	-
97980058*	-10 dB(A)	1	1610	1740	1190	500	380	37,5	462,5	24,5	-	950	1700	210	-	380	-	190	-
97980059	-20 dB(A)	1	1560	1645	1190	500	380	37,5	462,5	245	-	950	1700	210	-	380	-	190	-
97980061	-20 dB(A)	2	1956	1945	1740	300	400	150	150	104	504	1450	1700	270	530	330	490	180	2540
97980063	-20 dB(A)	2	2180	1950	1830	350	410	175	175	85	480	1400	1200	310	580	345	505	195	2765

Note:  
For gas burners in case of gas train up outlet it is necessary to install a 200 mm long cilindric extension.  
\*) To decrease the sound pressure by 20 dB(A) please contact our sales office.

**ATTENTION:**

It's customer responsibility to check the correct matching of soundproof according to the height of the boiler.

# GAS TRAIN STRUCTURE AND COMPOSITION

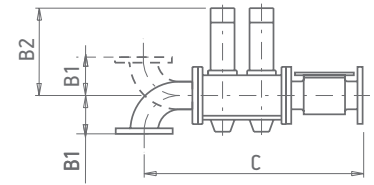
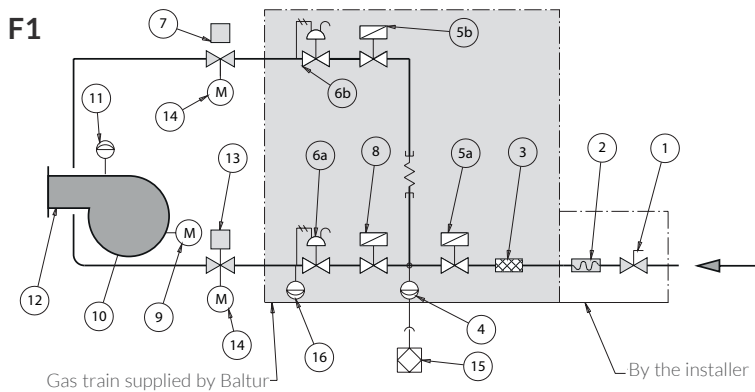

Pic. 1

Gas train Part no.	Position											Gas train dimensions mm			Size of packaging mm	Weight	Pic.
	CTV	F	Pmax	Pmc	VF	VF2	VLR	VS	R2	VS2	Ø	B1	B2	C	L x P x H	kg	
19990667 (VDG20.503)	●	2"	●	●	◆	◆	●	●	●	●	2"	165	278	755	990x300x500	23	1
19990668 (VDG40.065)	●	DN65	●	●	◆	◆	●	●	●	●	DN65	165	302	784	1380x430x700	36	1
19990675 (VDG20.503)	●	2"	●	●	◆	◆	●	●	●	●	2"	135	279	871	990x300x500	27	1
19990676 (VDG40.065)	●	DN65	●	●	◆	◆	●	●	●	●	DN65	131	303	969	1380x430x700	40	1
19990677 (VDG40.080)	●	DN80	●	●	◆	◆	●	●	●	●	DN80	131	313	1004	1380x430x700	42	1
19990678 (VDG40.100)	●	DN100	●	●	◆	◆	●	●	●	●	DN100	163	331	1096	1380x430x700	48	1
19990734 (MMBE065)	●	DN65	●	●	◆	◆	●	●	●	●	DN65	105	380	970	1380x430x700	36	1
19990762 (MMBE065)	●	DN65	●	●	◆	◆	●	●	●	●	DN65	105	380	970	1380x430x700	40	1
19990763 (MMBE080)	●	DN80	●	●	◆	◆	●	●	●	●	DN80	105	380	1005	1380x430x700	42	1
19990764 (MMBE100)	●	DN100	●	●	◆	◆	●	●	●	●	DN100	110	380	1095	1380x430x700	48	1

**CTV** Valve tightness control.  
**F** Filter.  
**LDU** LDU valve tightness control.  
**Pct** Pressure switch for gas control.  
**Pmax** Maximum pressure switch.  
**Pmc** Minimum and control pressure switch gas leaks.  
**Pmin** Minimum pressure switch.  
**R** Pressure regulator.  
**RF** Pressure regulator with filter.

**RFP** Pressure regulator with filter for pilot gas train.  
**RM** Manual flow rate regulator.  
**RP** Pneumatic regulator.  
**VF** Regulator throttle valve.  
**VL** Operating valve.  
**VL2** Two-stage operating valve.  
**VLP** Operating pilot valve.  
**VLR** Operating valve with pressure regulator.

**VP** Pilot valve.  
**VPS** VPS valve tightness control.  
**VS** Safety valve.  
**VSP** Safety pilot valve.  
**Ø** Gas train diameter.  
**Ø1** Main gas train diameter.  
**Ø2** Pilot gas train diameter.

● As Standard.  
 ▲ As standard for burners with an output of more than 1200 kW, on request for burners with an output of less than 1200 kW.  
 ■ On request.  
 ◆ Mounted on burner.



**baltur** **75**   
Energy for People  
[www.baltur.com](http://www.baltur.com)  
1950 - 2025

**Baltur S.p.A.**  
Via Ferrarese, 10  
44042 Cento (FE) - Italy  
Tel. +39 051 684.37.11  
[info@baltur.it](mailto:info@baltur.it)

**Sistema de Calidad Certificado**  
**UNI-EN ISO 9001 I.C.I.M. n° 202**

Los datos citados en este catálogo no son vinculantes; Baltur se reserva el derecho de realizar cambios sin previo aviso.