

# AL-6

Full bore type	Lift type	Safety valve	Relief valve
Safety relief valve	Lever type	Closed type	Dash-pot structure
Handle type	Stainless	High pressure gas testing products	
Diaphragm	Non-leakage		



## ■Features

1. Due to lift lever mechanism, a discharge inspection can be manually performed at more than 75% of the opening pressure.

## ■Specifications

Structure	Open type with a lever	
Application	Steam	
Working pressure	0.05-1.5 MPa *1	
Maximum temperature	220°C	
Material	Spring case	Ductile cast iron
	Valve, valve seat	Cast stainless steel
Connection	JIS 10K FF flanged JIS 16K FF flanged *2	

\*1 Maximum working pressure for 150A is 0.8 MPa. (JIS 10KFF)

\*2 JIS 16K FF flanged when working pressure is more than 1.0 MPa.

· Please refer to the chart in P. 81-80 for set pressure range.

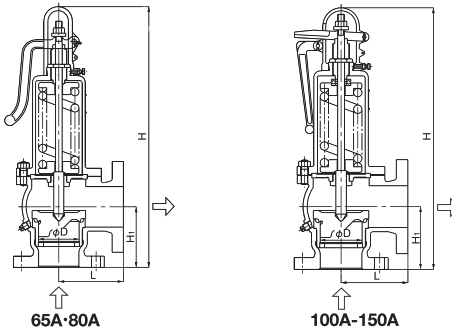

## ■Dimensions and Weights

Nominal size	Dimension (mm)				Flow area $\pi D^2$ (mm <sup>2</sup> )	Weight (kg)
	L	H <sub>1</sub>	H	D		
65A	120	120	479	65	331.9	20.2
80A	130	130 (132)	493 (495)	75	441.8	24.0
100A	160	150 (152)	626 (628)	100	785.4	44.0
125A	200	205 (207)	835 (837)	125	1227.2	88.0
150A	210	215	893	150	1767.2	113.0

· The values in parentheses are the dimensions of JIS 16K FF flanged.

■ Certified Capacity Table for AL-6

· For steam (saturation temperature) <Pressure vessel structure standard>

(kg/h)

Pressure MPa Nominal size	0.05	0.1	0.2	0.3	0.4	0.5	0.6	0.7	0.8	0.9	1.0	1.1	1.2	1.3	1.4	1.5
65A	263	340	493	663	834	1000	1165	1328	1489	1651	1814	1976	2138	2299	2461	2621
80A	350	452	657	882	1111	1331	1550	1767	1983	2198	2415	2631	2846	3060	3276	3489
100A	622	804	1168	1569	1975	2367	2756	3142	3525	3908	4294	4677	5059	5440	5825	6203
125A	972	1257	1826	2451	3086	3699	4307	4910	5508	6107	6709	7309	7906	8500	9102	9692
150A	1400	1810	2629	3530	4445	5327	6203	7071	7932							

<Boiler structure standard>

(kg/h)

Pressure MPa Nominal size	0.05	0.1	0.2	0.3	0.4	0.5	0.6	0.7	0.8	0.9	1.0	1.1	1.2	1.3	1.4	1.5
65A	255	332	486	640	796	947	1101	1254	1407	1557	1710	1862	2013	2164	2317	2469
80A	339	442	647	851	1059	1261	1466	1670	1873	2073	2276	2479	2680	2881	3084	3286
100A	604	786	1150	1514	1884	2242	2607	2968	3330	3686	4047	4407	4765	5122	5483	5843
125A	944	1228	1797	2366	2944	3504	4074	4638	5204	5760	6324	6886	7446	8003	8567	9129
150A	1359	1769	2588	3407	4239	5046	5866	6680	7494							

· Please refer to P. 8-12 for the calculation procedure for nominal size selection.

■ At the time of ordering

· When ordering, please specify the usage either pressure vessel or boiler structure.